

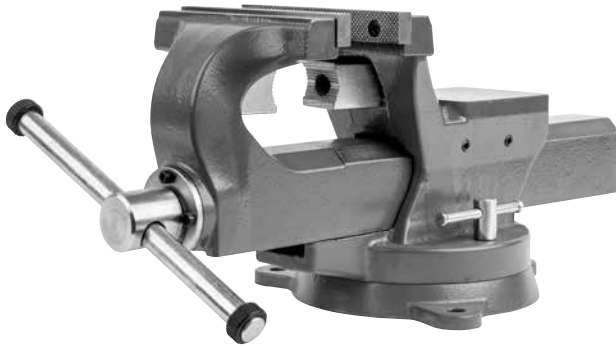

Industrial Duty Bench Vises

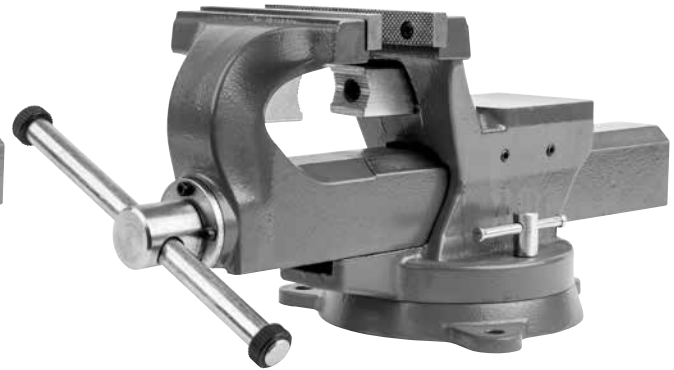

63004
4" Vise



63005
5" Vise



63006
6" Vise

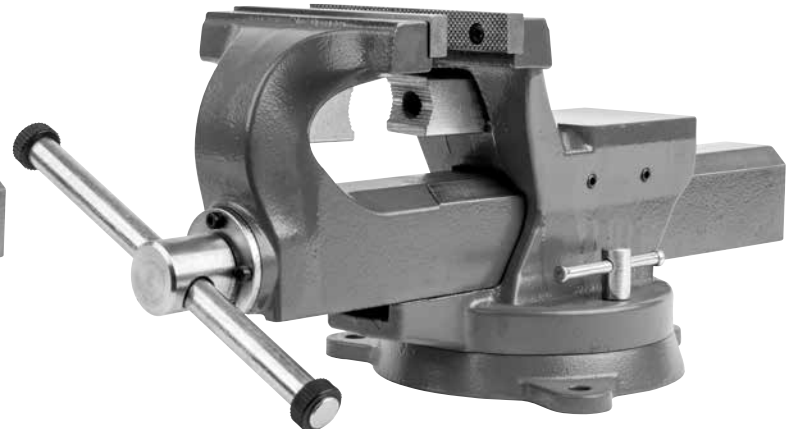

63008
8" Vise

Owner's Manual & Safety Instructions

THIS INSTRUCTION MANUAL CONTAINS IMPORTANT SAFETY INFORMATION. READ CAREFULLY AND UNDERSTAND ALL INFORMATION BEFORE OPERATING THIS TOOL! SAVE THIS MANUAL FOR FUTURE REFERENCE.

Warranty Registration - <https://www.kentool.com/vise-registration>

⚠ IMPORTANT SAFETY INSTRUCTIONS

Failure to follow these instructions could lead to serious injury.



- Do not use this vise until properly mounted as described in the Vise Mounting Section of this manual.

- Do not use while you are tired or under the influence of drugs, alcohol, or medication.



- Wear ANSI approved safety glasses and heavy-duty work gloves during use.

- Make sure work area is well lit and clean of oils and debris.

- Keep area clear of bystanders during use.

⚠ WARNING

This product can expose you to chemicals including lead which is know to the State of California to cause cancer and birth defects or other reproductive harm. For more information go to <http://www.p65warnings.ca.gov>. WASH HANDS THOROUGHLY AFTER HANDLING.

WISE MOUNTING

- Use the mounting holes on the base of the vise as a template to mark drill points. Set the vise flat on the workbench so that the mounting holes are positioned as desired. With a marking device, mark the points at which to fasten the vise to the workbench. Set the vise aside.
- Prior to drilling the mounting holes, check for hidden electrical wires or cords in the drilling path.
- Drill holes to the appropriate size where previously marked on top of the workbench.
- NEVER weld your vise to a workbench.
- Set the base of the vise over the drilled mounting holes.
- Insert appropriate steel bolts (not provided) of the appropriate diameter and length downward through the base of the workbench. Secure the mounting bolts with the appropriate nuts, lock, and flat washers.

OPERATION

- Loosen the two base handles to allow the base to pivot to the position you want to work with. Tighten the base handles prior to use.
- Turn the vise spindle counterclockwise to open the jaws of the vise.
- Place the workpiece in the jaws.
- Tighten the jaws by turning the vise spindle clockwise to secure your workpiece. Never use a hammer, cheater bar, pipe extension bar on the spindle or base handle of the vise.

WISE USE

- Always select a vise of proper size and capacity to hold your specific work object.
- Never use a hammer, cheater bar, pipe extension bar on the spindle or base handle of the vise.
- Never unscrew movable jaw beyond the maximum specified opening of the vise.
- Never use vise as a press for disassembly or assembly of objects.
- When working with anvil, do not strike it directly with a hardened tool. It could chip the anvil or the tool.

MAINTENANCE

- Keep the moving parts lubricated. Wipe any excess lubrication off the jaws and or all handles.
- Keep the jaws clean.
- The jaws can be removed for cleaning and replacement. Each is held with cap screws.
- Periodically check that the mounting bolts have not loosened. Tighten, as necessary.

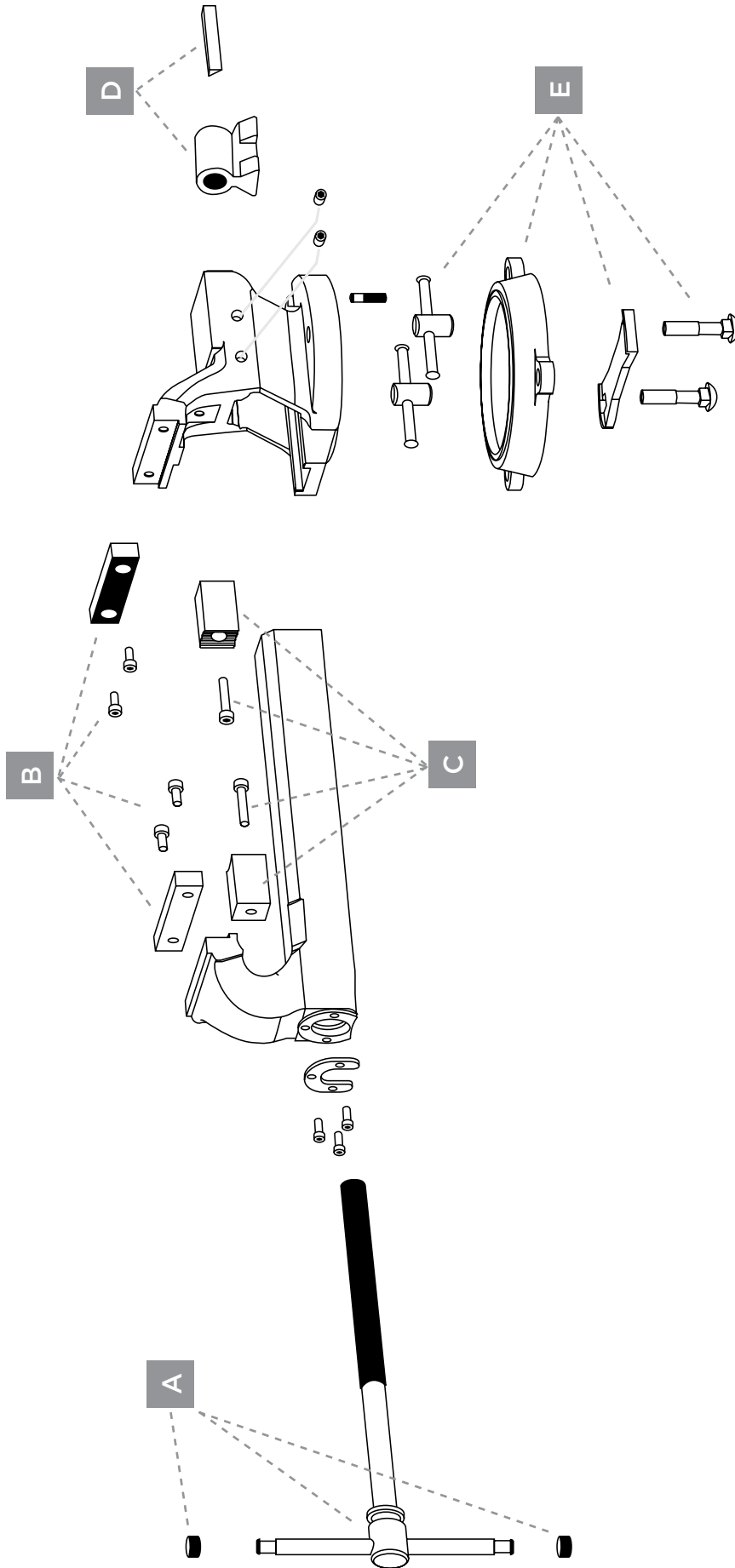

Item	Part No.	Description
63008		KEN-TOOL INDUSTRIAL DUTY 8 IN BENCH VISE
A	63008-01	MAIN SCREW
B	63008-02	JAW PLATE SET
C	63008-03	PIPE JAW SET
D	63008-04	INSIDE NUT SET
E	63008-05	SWIVEL BASE SET

Item	Part No.	Description
63006		KEN-TOOL INDUSTRIAL DUTY 6 IN BENCH VISE
A	63006-01	MAIN SCREW SET
B	63006-02	JAW PLATE SET
C	63006-03	PIPE JAW SET
D	63006-04	INSIDE NUT SET
E	63006-05	SWIVEL BASE SET

Item	Part No.	Description
63005		KEN-TOOL INDUSTRIAL DUTY 5 IN BENCH VISE
A	63005-01	MAIN SCREW SET
B	63005-02	JAW PLATE SET
C	63005-03	PIPE JAW SET
D	63005-04	INSIDE NUT SET
E	63005-05	SWIVEL BASE SET

Item	Part No.	Description
63004		KEN-TOOL INDUSTRIAL DUTY 4 IN BENCH VISE
A	63004-01	MAIN SCREW SET
B	63004-02	JAW PLATE SET
C	63004-03	PIPE JAW SET
D	63004-04	INSIDE NUT SET
E	63004-05	SWIVEL BASE SET

PLEASE REVIEW ALL WARNING INSTRUCTIONS PRIOR TO OPERATION. SAVE THIS MANUAL FOR FUTURE REFERENCE.



SEE OUR VIDEO DEMOS AT
WWW.KENTOOL.COM

www.KENTOOL.com

1-888-536-8665

© 2021 Ken-Tool. All Rights Reserved. | 768 E. North Street, P.O. Box 9320 | Akron, Ohio 44305
Fax: 800-872-4929 | Phone: 330-535-7177 | Fax: 330-535-1345 | E-mail: sales@kentool.com

65005
2021-08-09